

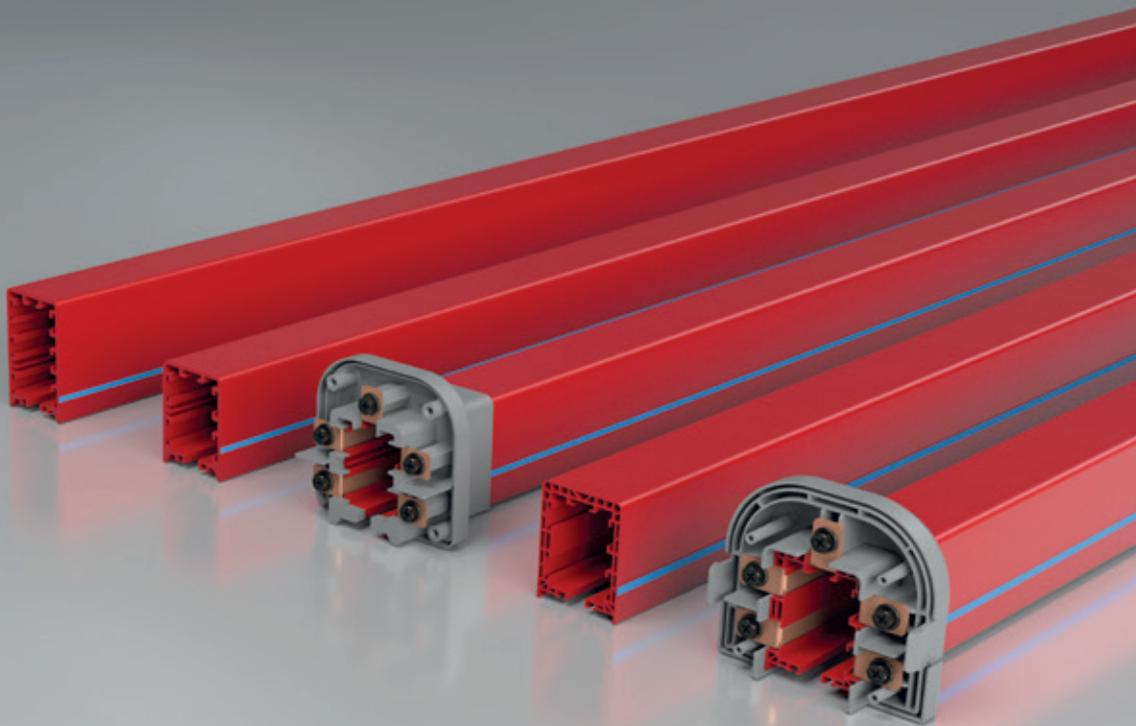

E-LINE TROLLEY BUSBAR

Trolley Busbar Systems



E-LINE TROLLEY BUSBAR

Please visit our website for the updated version of our catalogues.
www.eaelectric.com



EAE Group in numbers;



1973
year of foundation

Founded in 1973, EAE Elektrik A.S. being the parent company of EAE Group is a worldwide manufacturer of electrical products.

Founded : in 1973
Closed Manufacturing Area : 280.000m²
Range of Products : Busbar Power Distribution Systems
Lighting Busbar Systems
Cable Tray Systems
Underfloor Trunking
Trolley Busbar Systems



280.000m²
closed manufacturing
area

Companies : EAE Elektrik
EAE Aydınlatma
EAE Elektroteknik
EAE Teknoloji
EAE Makina



5
manufacturing
plants

Number of Plants : 5

“Lean Production” and “Innovative and Customer Driven Product Development” approaches are the key values utilized in designing and manufacturing the product families in compliance with ISO 9001, ISO 14001, OHSAS 18001 and ISO 27001.



3
R&D Centers

EAE Elektrik A.S. busbar products are certified by KEMA/DEKRA (Holland), KEMA - KEUR, UL classified laboratories as per IEC 61439-1/6 standards.



100+
countries of export



• Bridge Cranes



• Monorail Systems



• Textile Cutting and Spreading Tables



• AS/RS Storage Systems



• Moving Ceiling and Door Systems

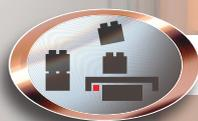

• Assembly and Test Lines



E-LINE TBE

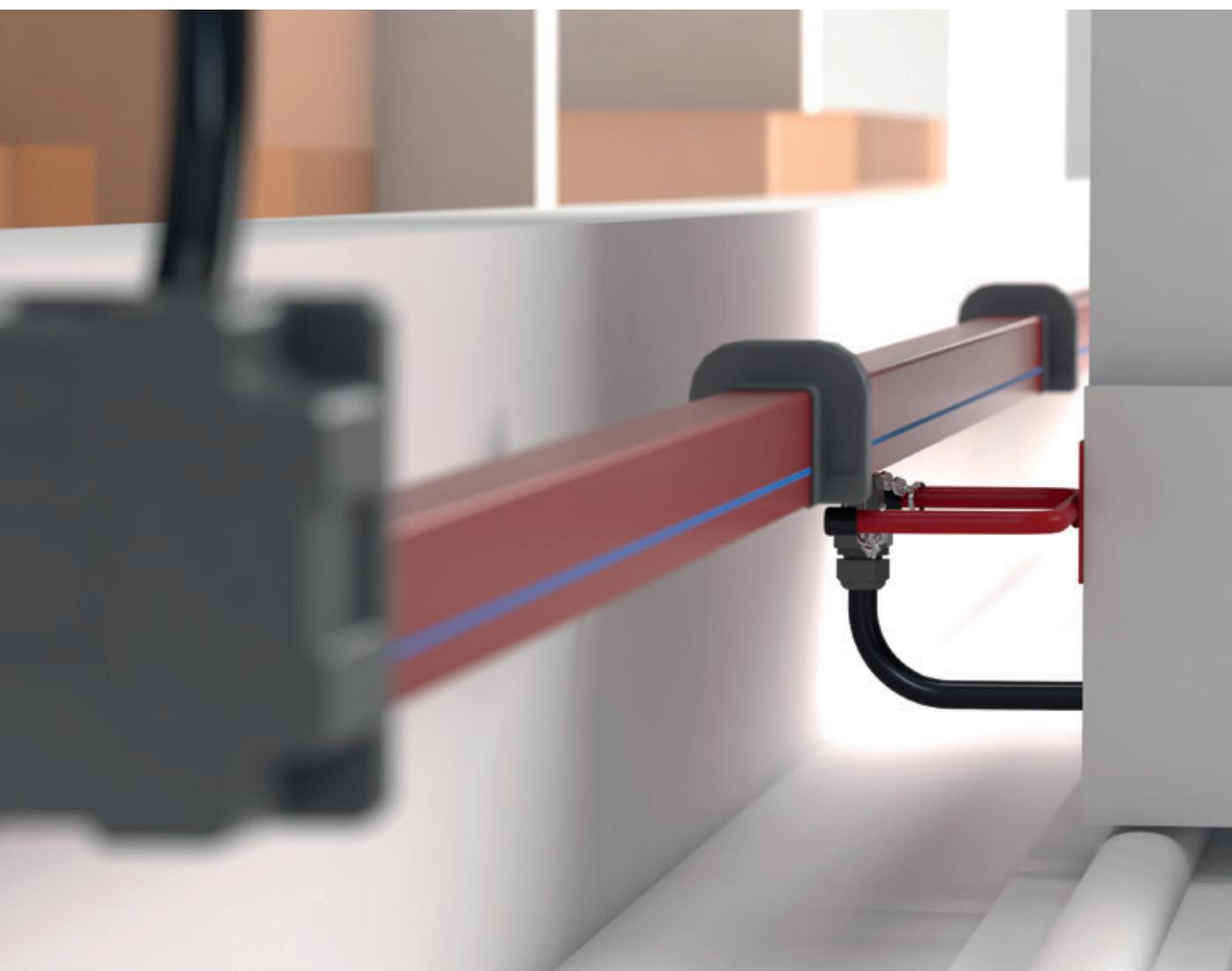

TBE

E-LINE TBE

Please visit our website for the updated version of our catalogues.
www.eaelectric.com



CONTENTS

▶▶ E-LINE TBE

Trolley Busbar Systems	2
Order Code System	3
TBE PVC Housing	4
TBE Feeder Unit	5-6
TBE Current Collector	7-8
System Components	9
Voltage Drop, Calculation Of Feeding Points	10
TBE Trolley Busbar Installation Manual	11

TBE

►► TROLLEY BUSBAR SYSTEMS

- Bridge Cranes
- Monorail Systems
- Textile Cutting and Spreading Tables
- AS/RS Storage Systems
- Moving Ceiling and Door Systems
- Assembly and Test Lines

It consists of copper conductors and current collectors in the C-PVC body. The uninterrupted energy supply and movement of the system is provided by current collectors connected to the system mechanically.

The eliminates the possibilities such as accident, malfunction in energy distribution with suspended and reel cable in conventional systems. Conductors are enclosed in C-PVC housing and personnel safety is maximized.

There is no fixed connection between the conductor housings and the conductors and between the C-PVC housing and the sliding hangers, the necessary expansion opportunity is provided, therefore the expansion element is unrequired.

Cautions:

If it is used in external environments exposed to rain, it is recommended to protect it with a cover such as a canopy.

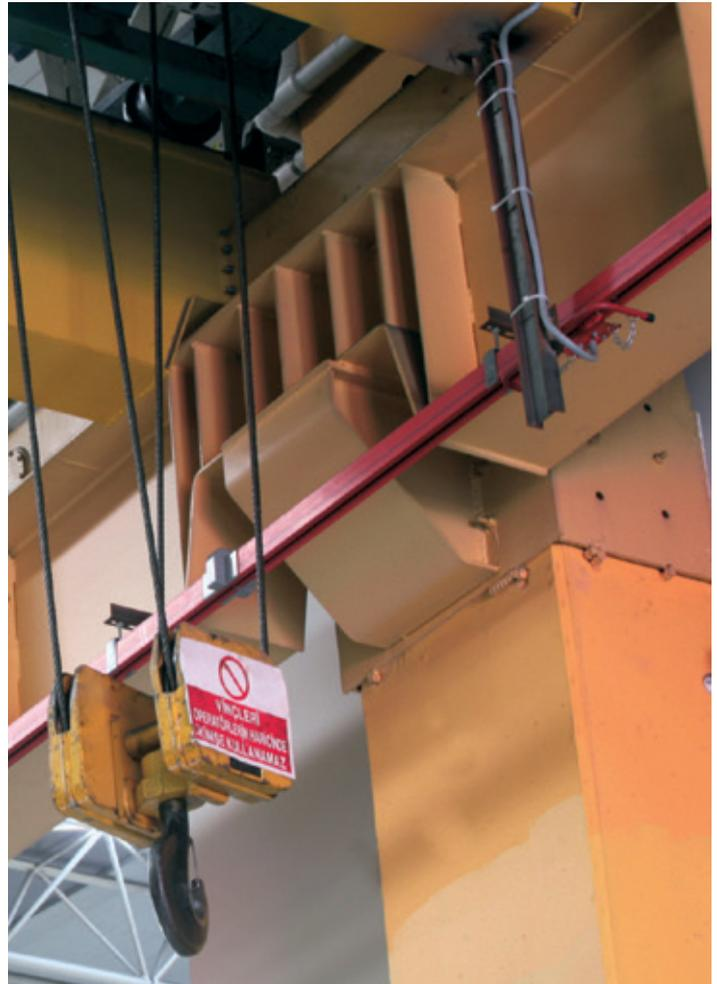

►► ORDER CODE SYSTEMS

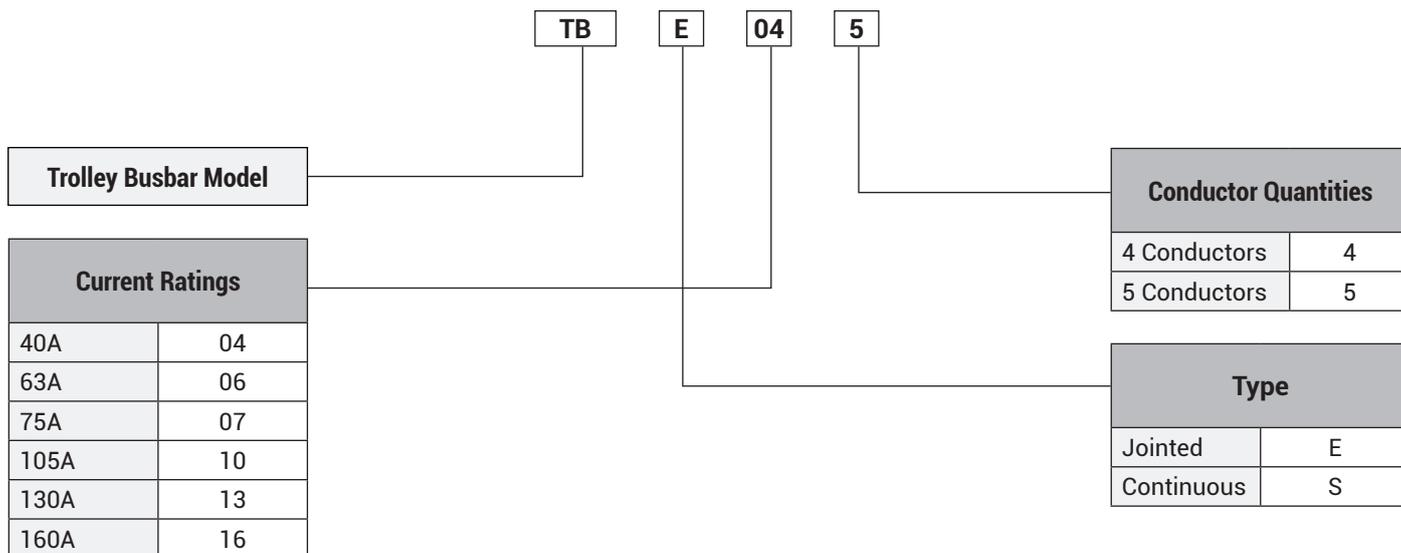

►► TECHNICAL FEATURES

Rated Current (A)		40	63	75	105	130	160
Conductor Quantities (pcs)		4-5	4-5	4-5	4-5	4-5	4-5
Rated Voltage (AC) (V)		690	690	690	690	690	690
Dielectric Properties (kV/mm)		30	30	30	30	30	30
Frequency (Hz)		50/60	50/60	50/60	50/60	50/60	50/60
Resistance (20°C) R ₂₀ (mΩ/m)		1,300	1,240	1,150	0,780	0,600	0,450
Resistance (35°C) R ₃₅ (mΩ/m)		1,420	1,425	1,340	0,910	0,700	0,530
Reactance X (mΩ/m)		0,160	0,130	0,110	0,130	0,130	0,110
Impedance Z (mΩ/m)		1,429	1,431	1,35	0,919	0,712	0,541
Standard Length (m)		4	4	4	4	4	4

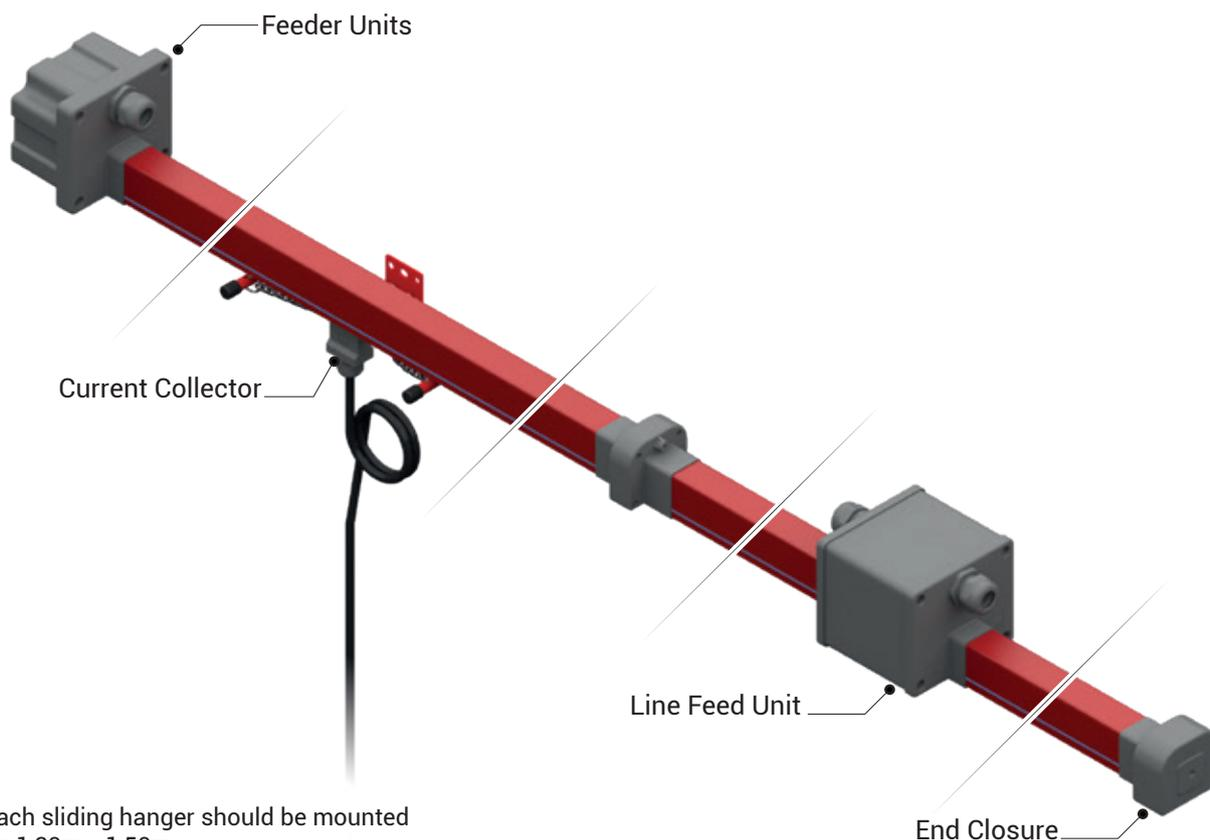

Note: Each sliding hanger should be mounted between 1,30m - 1,50m.

▶▶ TBE TROLLEY BUSBAR

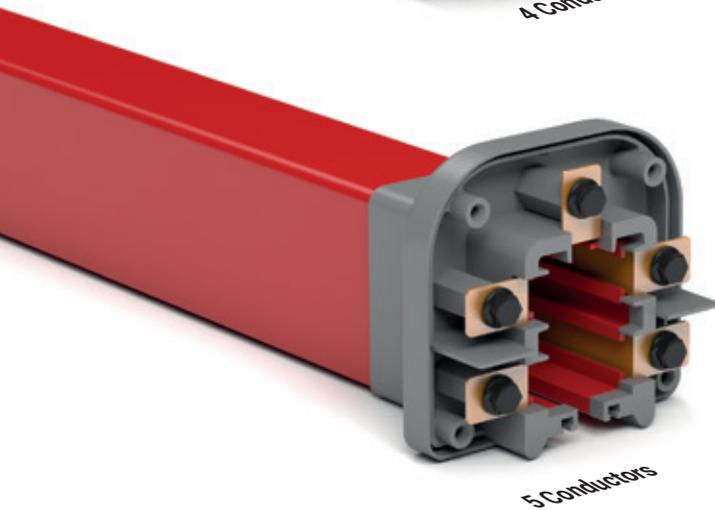
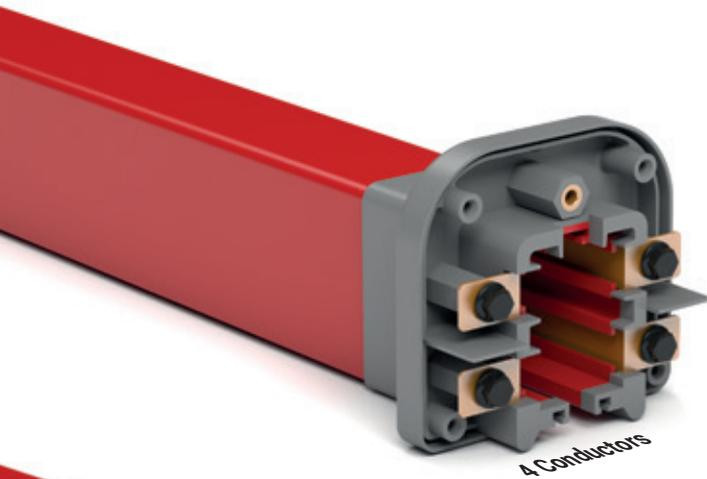

- **Number of Conductors:** 4 or 5 conductors
- **Colour:** Red.
- **Temperature range:** -40°C , +55°C.
- **Standard housing length:** 4 meters.
- **Protection:** IP24
- **Non-Flammable Characteristics:** UL 94 V0
- Housing is made of C-PVC and plastic accessories are made of PA6 raw material.
- There is a neutral line on the housing the neutral conductor.

Standard 4 Meters

Model	Conductors Quantity-Current (A)	Weight (gr/m)	Conductor Cross Section (mm ²)	Order Code
TBE 044	4P - 40A	1950	4x11,20	3024446
TBE 064	4P - 63A	2000	4x12,80	3179770
TBE 074	4P - 75A	2100	4x16,00	3024449
TBE 104	4P - 105A	2250	4x24,00	3024447
TBE 134	4P - 130A	2650	4x32,00	3024448
TBE 164	4P - 160A	2900	4x40,00	3158671
TBE 045	5P - 40A	2100	5x11,20	3024435
TBE 065	5P - 63A	2150	5x12,80	3179771
TBE 075	5P - 75A	2200	5x16,00	3024436
TBE 105	5P - 105A	2550	5x24,00	3024437
TBE 135	5P - 130A	2950	5x32,00	3024438
TBE 165	5P - 160A	3250	5x40,00	3164949

Description	Weight (gr/m)	Order Code
TB5 Trolley Busbar	1250	2037290

The housing has a structure that can use maximum 5 conductors. There is safety system that prevents the current collector to be fixed inversely.

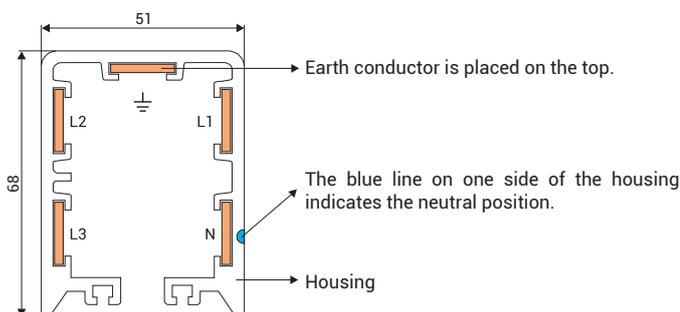
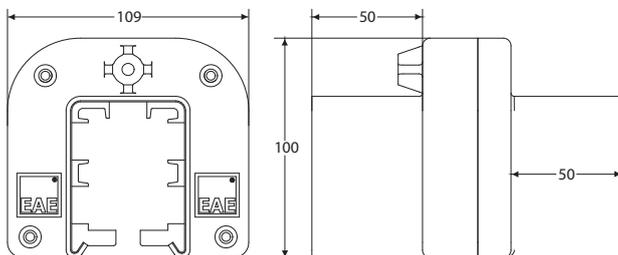

Special Length 1 or 2, 3 Meters

Model	Conductors Quantity-Current (A)	Weight (gr/m)	Conductor Cross Section (mm ²)	Order Code
TBE 044	4P - 40A	1950	4x11,20	3024473
TBE 064	4P - 63A	2000	4x12,80	3179774
TBE 074	4P - 75A	2100	4x16,00	3024475
TBE 104	4P - 105A	2250	4x24,00	3024477
TBE 134	4P - 130A	2650	4x32,00	3024479
TBE 164	4P - 160A	2900	4x40,00	3158668
TBE 045	5P - 40A	2100	5x11,20	3024474
TBE 065	5P - 63A	2150	5x12,80	3179775
TBE 075	5P - 75A	2200	5x16,00	3024476
TBE 105	5P - 105A	2550	5x24,00	3024478
TBE 135	5P - 130A	2950	5x32,00	3024480
TBE 165	5P - 160A	3250	5x40,00	3164946

Joint plastics are not included in the weight values. Total weight of the joint plastics and bolts is 0.27 Kg.

►► TBE FEEDER UNITS

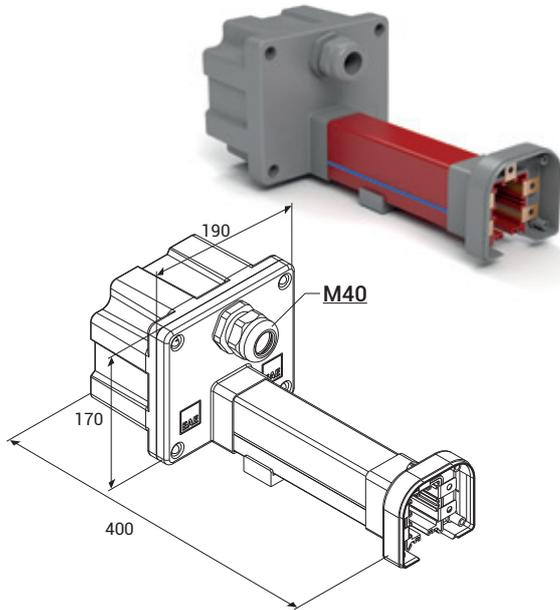

Model	Conductors Quantity-Current (A)	Weight (gr/m)	Conductor Cross Section (mm ²)	Order Code
TBE 044	4P - 40A	1250	4x11,20	3024431
TBE 064	4P - 63A	1300	4x12,80	3179768
TBE 074	4P - 75A	1350	4x16,00	3024432
TBE 104	4P - 105A	1400	4x24,00	3024433
TBE 134	4P - 130A	1500	4x32,00	3024434
TBE 164	4P - 160A	1600	4x40,00	3158669
TBE 045	5P - 40A	1300	5x11,20	3024459
TBE 065	5P - 63A	1350	5x12,80	3179769
TBE 075	5P - 75A	1400	5x16,00	3024423
TBE 105	5P - 105A	1500	5x24,00	3024424
TBE 135	5P - 130A	1600	5x32,00	3024445
TBE 165	5P - 160A	1700	5x40,00	3164947

►► TBE LINE FEED UNITS

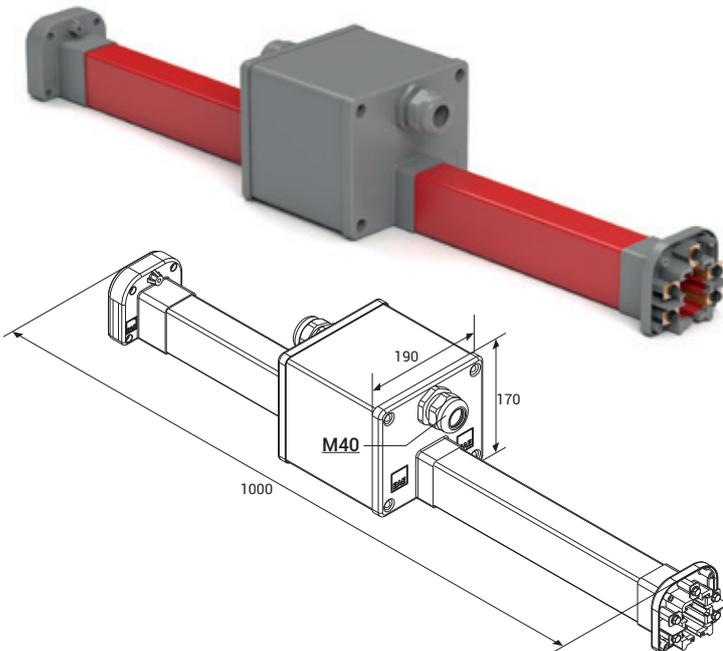

Model	Conductors Quantity-Current (A)	Weight (gr/m)	Conductor Cross Section (mm ²)	Order Code
TBE 044	4P - 40A	2750	4x11,20	3024439
TBE 064	4P - 63A	2800	4x12,80	3179778
TBE 074	4P - 75A	2900	4x16,00	3024440
TBE 104	4P - 105A	3200	4x24,00	3024441
TBE 134	4P - 130A	3450	4x32,00	3024442
TBE 164	4P - 160A	3750	4x40,00	3158670
TBE 045	5P - 40A	2850	5x11,20	3024460
TBE 065	5P - 63A	2900	5x12,80	3179779
TBE 075	5P - 75A	3000	5x16,00	3024425
TBE 105	5P - 105A	3350	5x24,00	3024426
TBE 135	5P - 130A	3750	5x32,00	3024427
TBE 165	5P - 160A	4100	5x40,00	3164948

Type of the feeding element is selected by calculating the voltage drop and the location of the power supply that shall provide power to the system.

►► TBE END CLOSURE

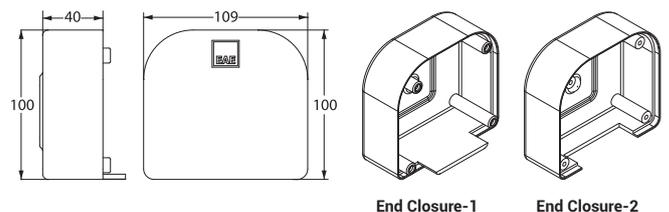
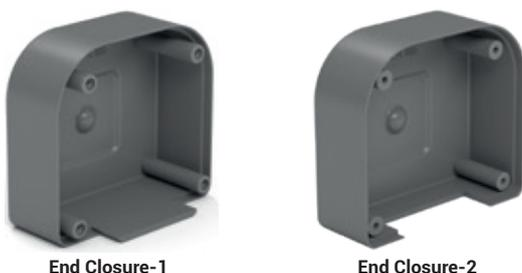

Description	Weight (gr)	Order Code
TBE End Closure-1 (Female)	100	3024420
TBE End Closure-2 (Male)	100	3241448

The end closure placed on the end of the busbar line prevents the exposure of the conductors, and protects the system.

►► TBE REPAIR ZONE UNIT

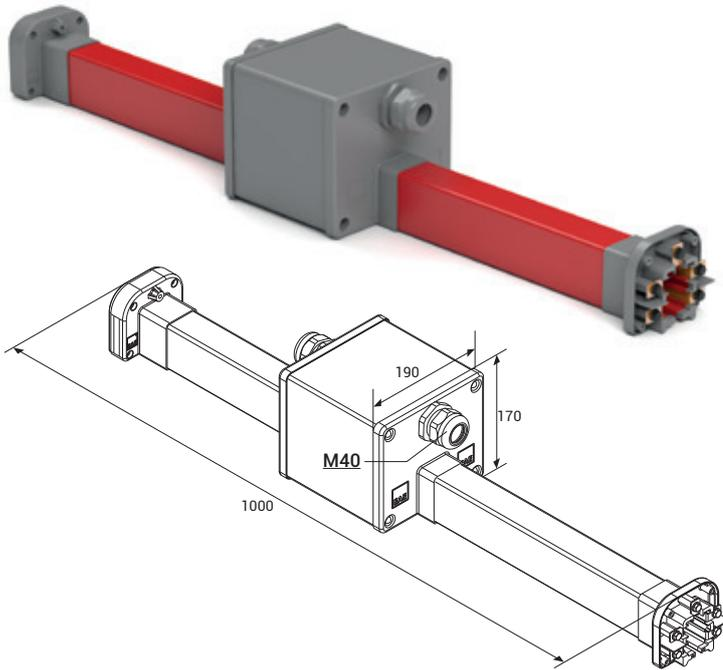

Model	Conductors Quantity-Current (A)	Weight (gr/m)	Conductor Cross Section (mm ²)	Order Code
TBE 044	4P - 40A	3500	4x11,20	3066688
TBE 064	4P - 63A	3550	4x12,80	3179780
TBE 074	4P - 75A	3600	4x16,00	3066689
TBE 104	4P - 105A	3900	4x24,00	3066690
TBE 134	4P - 130A	4200	4x32,00	3066691
TBE 164	4P - 160A	4450	4x40,00	3164950
TBE 045	5P - 40A	3600	5x11,20	3066692
TBE 065	5P - 63A	3650	5x12,80	3179781
TBE 075	5P - 75A	3750	5x16,00	3066693
TBE 105	5P - 105A	4100	5x24,00	3066694
TBE 135	5P - 130A	4500	5x32,00	3066695
TBE 165	5P - 160A	4800	5x40,00	3164952

Current supply shall be cut off when a machine working on the line shall be maintained or repaired. Repair zone module is used to create a currentless area on the busbar so that the other machines operating on the same line may continue to work.

►► TBE CURRENT COLLECTOR REPLACEMENT MODULE

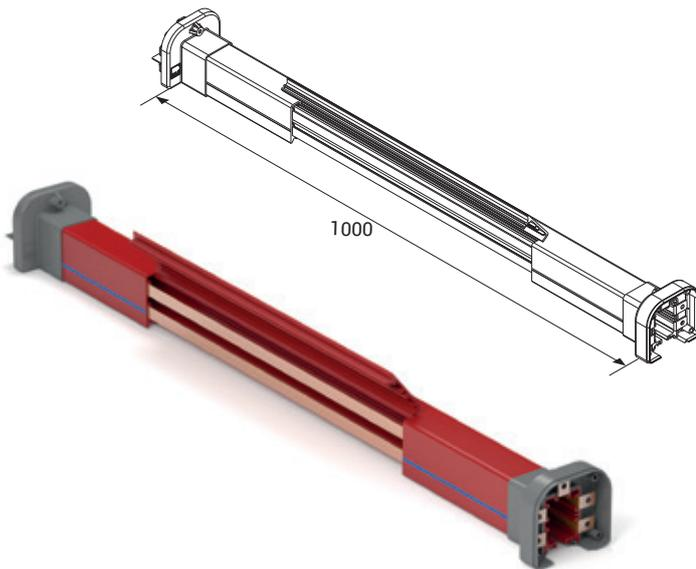

Model	Conductors Quantity-Current (A)	Weight (gr/m)	Conductor Cross Section (mm ²)	Order Code
TBE 044	4P - 40A	2000	4x11,20	3024558
TBE 064	4P - 63A	2050	4x12,80	3179784
TBE 074	4P - 75A	2100	4x16,00	3024897
TBE 104	4P - 105A	2400	4x24,00	3024898
TBE 134	4P - 130A	2700	4x32,00	3024899
TBE 164	4P - 160A	3000	4x40,00	3164951
TBE 045	5P - 40A	2100	5x11,20	3024421
TBE 065	5P - 63A	2150	5x12,80	3179785
TBE 075	5P - 75A	2250	5x16,00	3024428
TBE 105	5P - 105A	2600	5x24,00	3024429
TBE 135	5P - 130A	3000	5x32,00	3024430
TBE 165	5P - 160A	3350	5x40,00	3164953

This unit is used to remove an existing current collector or to add extra trolleys. The unit is obtained by cutting a 50cm section from the PVC housing.

►► **TB5 CURRENT COLLECTORS WITH CABLE**

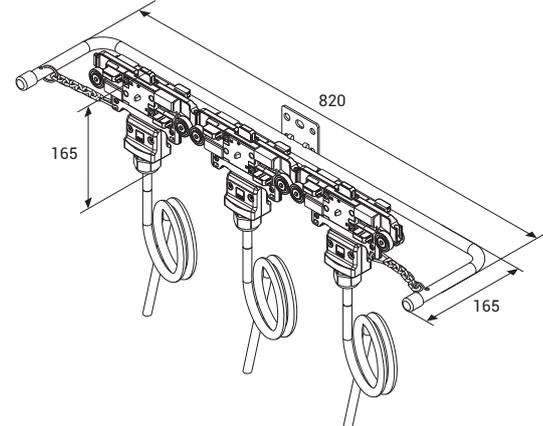
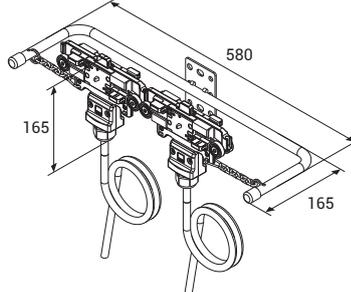
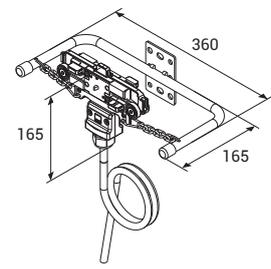

Model	Brushes Number-Current (A)	Weight (gr)	Order Code
TB5	4P - 35A (Single)	1700	3024385
	4P - 70A (Double)	2950	3024386
	4P - 105A (Triple)	4450	3024387
	5P - 35A (Single)	1900	3024376
	5P - 70A (Double)	3250	3024377
	5P - 105A (Triple)	4700	3024378

Model	Brushes Number-Current (A)	Weight (gr)	Order Code
TB5	4P - 60A (Single)	2000	3203193
	4P - 120A (Double)	3550	3269558
	5P - 60A (Single)	2200	3203194
	5P - 120A (Double)	3850	3269559

►► **TB5 CURRENT COLLECTORS WITH CLIP**

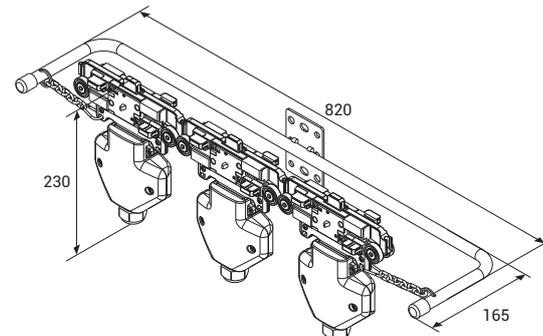
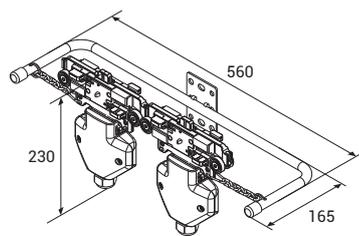
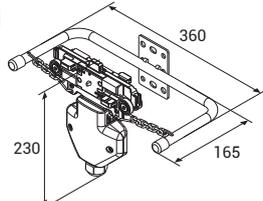
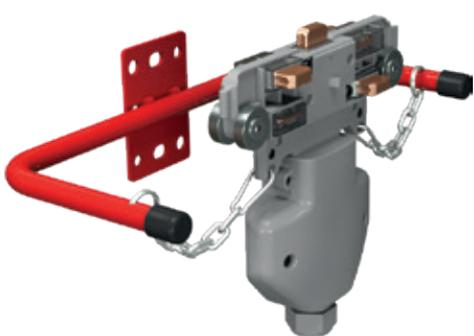

Model	Brushes Number-Current (A)	Weight (gr)	Order Code
TB5	4P - 35A (Single)	1350	3024388
	4P - 70A (Double)	2050	3024389
	4P - 105A (Triple)	3050	3024390
	5P - 35A (Single)	1350	3024379
	5P - 70A (Double)	2250	3024380
	5P - 105A (Triple)	3200	3024381

*Produced with standard M40 cable gland and 4mm² clip.

Current collector with clips allow the customers to perform cabling as they desire with the clips they include. Current collector are the moving elements of the trolley busbar systems. Current collector brushes rub against the conductors and draw continuous current while they move through the busbar line. They adapt to shaky and vibrant conditions thanks to the moving brushes. As current collecting and transfer systems are included in the C-PVC housing, they are protected against human contact.

TBE

▶▶ TB5 CURRENT COLLECTOR WITH FUSE BOX

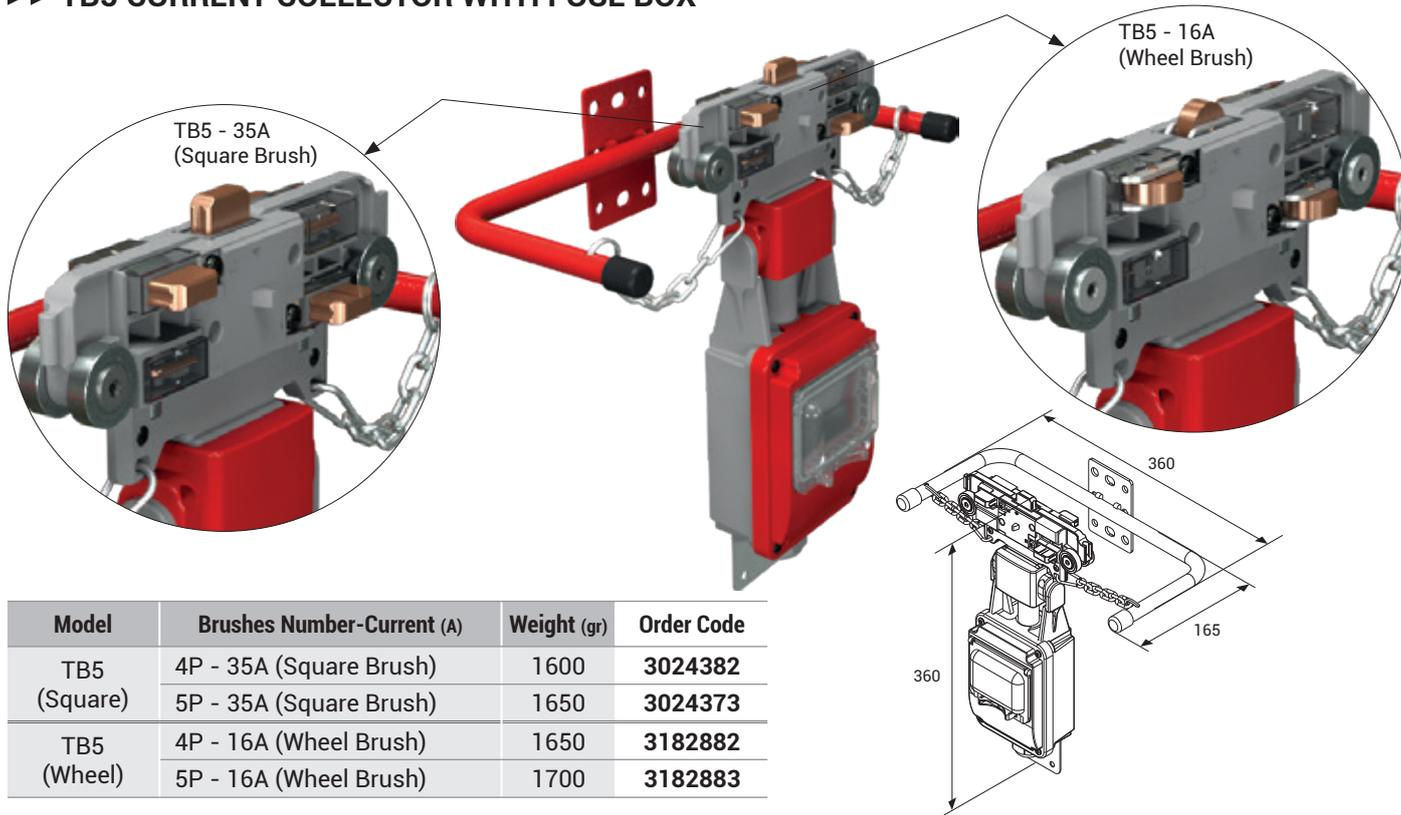

Model	Brushes Number-Current (A)	Weight (gr)	Order Code
TB5 (Square)	4P - 35A (Square Brush)	1600	3024382
	5P - 35A (Square Brush)	1650	3024373
TB5 (Wheel)	4P - 16A (Wheel Brush)	1650	3182882
	5P - 16A (Wheel Brush)	1700	3182883

Fuse boxed with both staff and current receiving area carts current machine's safety can be raised to a higher level. In addition, when it is desired to cut the power of one of the machines on a line, the current is cut off through the fuse, other machines on the line can continue to operate.

Current collector with Wheel Brush simplify the movement of the current collectors inside the busbar by reducing the time at the installation tables when movement is provided by the personnel.

TB5 Current collector models operating speed is max. 100m/min.

▶▶ TB5 CURRENT COLLECTOR BRUSHES

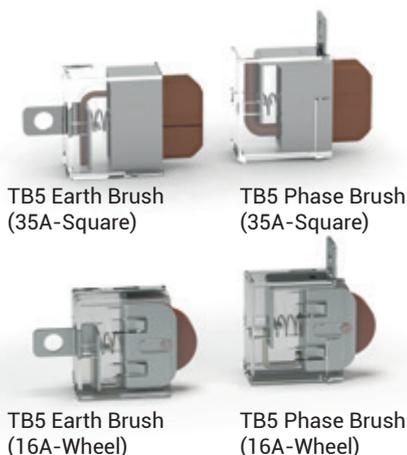

Description	Weight (gr)	Order Code
TB5 Phase Brush (35A-Square)	40	3024371
TB5 Earth Brush (35A-Square)	40	3024372
TB5 Phase Brush (16A-Wheel)	40	3165078
TB5 Earth Brush (16A-Wheel)	40	3165080

▶▶ TB5 TROLLEY TRANSFER TOOL

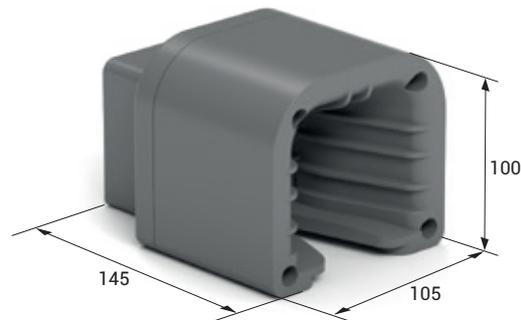

Description	Weight (gr)	Order Code
TB5 Trolley Transfer Tool	250	3179189

▶▶ **TB5 PLASTIC SLIDING HANGER**

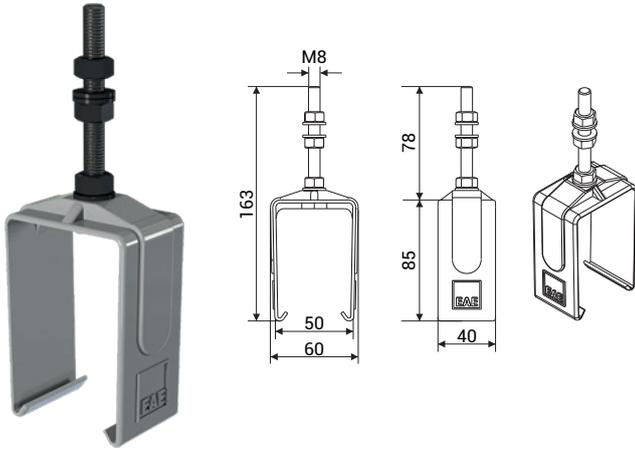

▶▶ **TB5 STEEL SLIDING HANGER**

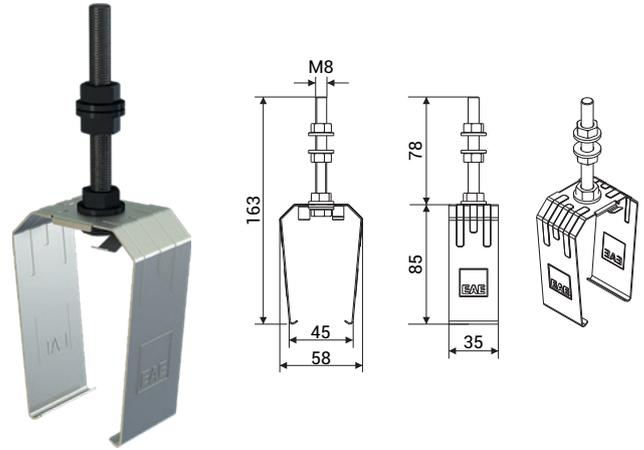

Trolley busbar should be mounted with sliding hangers and each hangers should be between 1,30m - 1,50m. Distance between sliding hanger and other units (joint unit, feeder etc.) should be minimum 300mm.

Description	Weight (gr)	Order Code
TB5 Plastic Sliding Hanger	85	1003664

Description	Weight (gr)	Order Code
TB5 Steel Sliding Hanger	100	1005954

▶▶ **TB HANGER BRACKET**

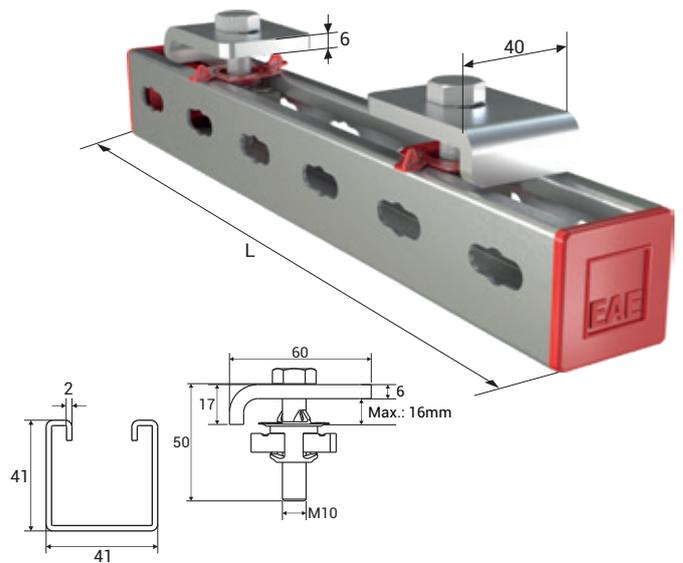
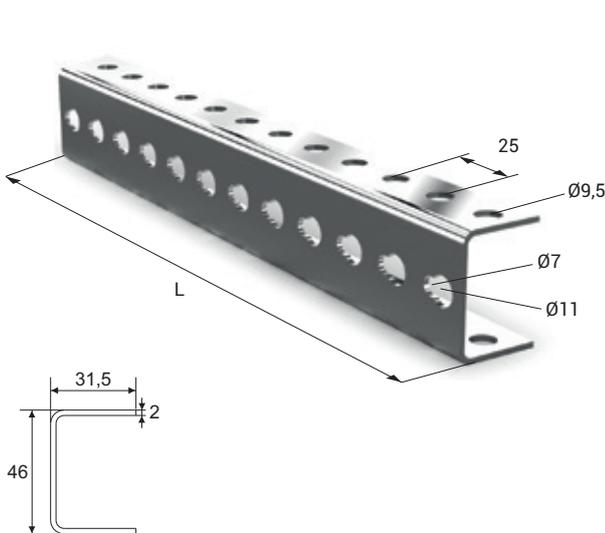

Description	L (mm)	Weight (gr)	Order Code
TB Hanger Bracket	250	350	3025153
URC-C/S Hanger Bracket	500	700	3034560
URC-A Hanger Bracket	750	1050	3025382

Description	L (mm)	Weight (gr)	Order Code
TB BR Hanger Bracket Set	300	800	3178916
URC-C/S BR Hanger Bracket Set	600	1250	3178917
URC-A BR Hanger Bracket Set	800	1550	3178918

►► **VOLTAGE DROP**

The voltage drop in the busbar lines shall be inspected as per the busbar type selected according to the total current calculated based on the ambient temperature and operating period of the system. Maximum acceptable value for voltage drop is 3%.

For Direct Current

$$\Delta U = 2 \cdot L_t \cdot I_G \cdot R$$

ΔU = Voltage Drop [V]

For Mono-Phase Alternative Current

$$\Delta U = 2 \cdot L_t \cdot I_G \cdot Z$$

I_G = Total current [A]

R = Resistance of the busbar [Ω/m]

For Three-Phase Alternative Current

$$\Delta U = \sqrt{3} \cdot L_t \cdot I_G \cdot Z$$

Z = Impedance of the busbar [Ω/m]

L_t = Calculated Hole Length [m]

Note : Calculation of the current drawn during first start in various motor types;

I_A = Total current drawn in the first start of the motors [A]

For the starting current; Three-phase asynchronous drive in direct start

Slip ring rotor motor

Frequency converter

I_A = I_G x calculated as 5 to 6

I_A = I_G x calculated as 2 to 3

I_A = I_G x 1,20 to 1,50 calculated between.

►► **CALCULATION OF FEEDING POINTS**

When we take L_t as the length of the line, feeding points may be selected as shown in the diagrams below to keep the L voltage drop at minimum and it may be used as the hole length for the calculation of L_t voltage drop.



1 feeding point from the start, $L_t=L$

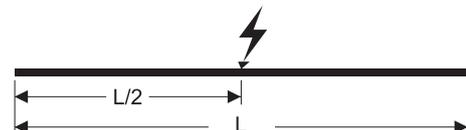

1 feeding point from the center, $L_t=L/2$



2 feeding points from the start points, $L_t=L/4$



2 feeding points, $L_t=L/6$

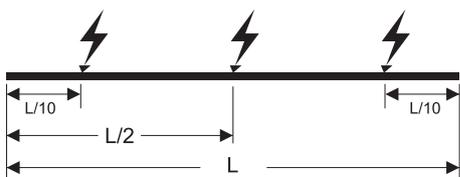

3 feeding points, $L_t=L/10$

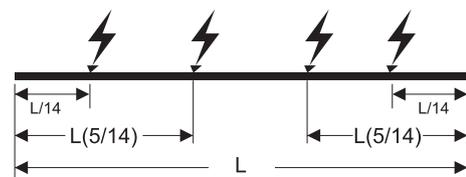

4 feeding points, $L_t=L/14$

►► INSTALLATION MANUAL

TBE - INSTALLATION OF JOINT UNIT

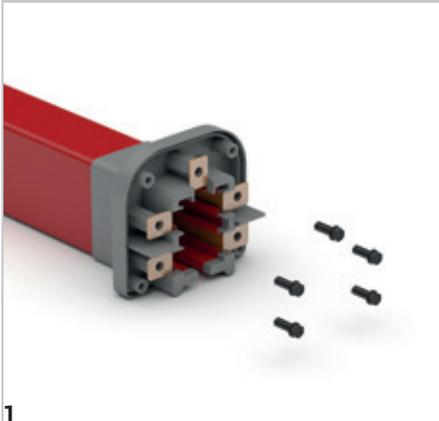

1 Remove the screws on the end of the busbar.

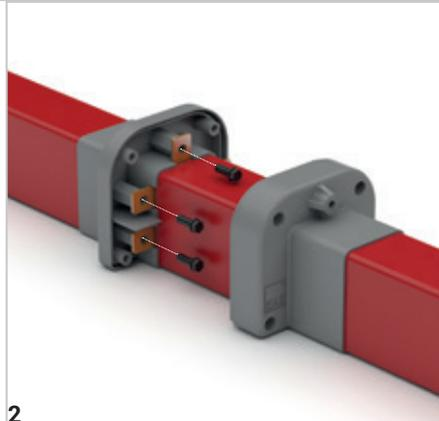

2 Join it with the other busbar and screw it.

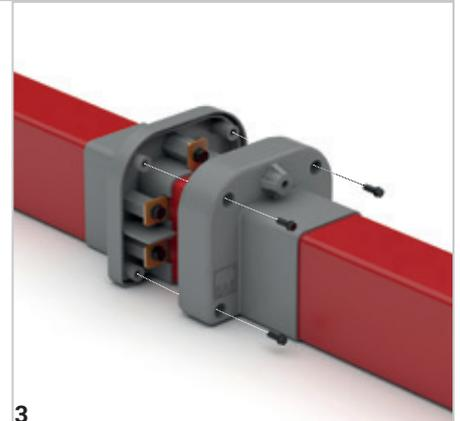

3 Close the joint cover and screw it.

TBE - FEEDER UNIT

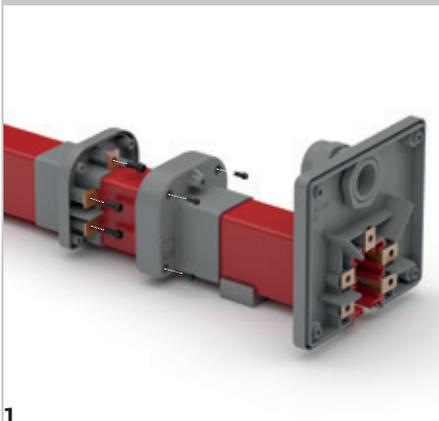

1 Install it on the line as you do while installing the extension.

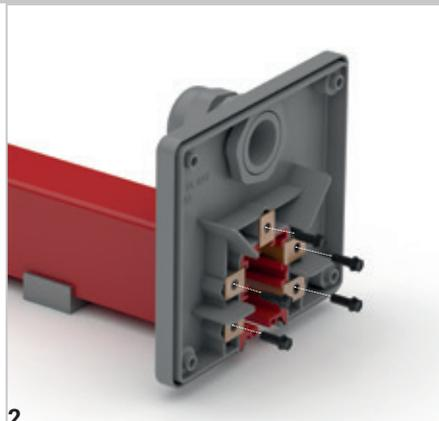

2 Put the feeding cables through the cable gland and connect them to the conductors.

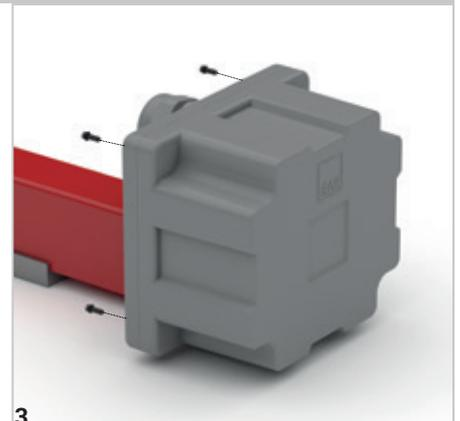

3 Place the cover part and screw it.

TBE - LINE FEED UNIT

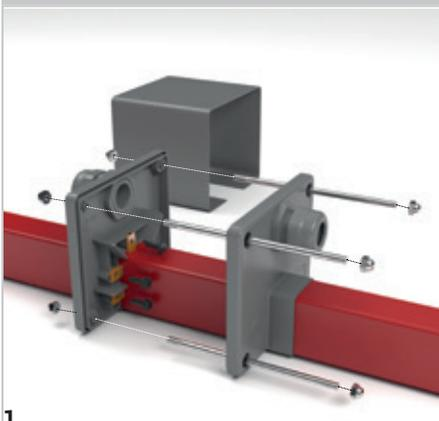

1 Open the cover by removing the screws. Put the feeding cables through the cable gland connect them.

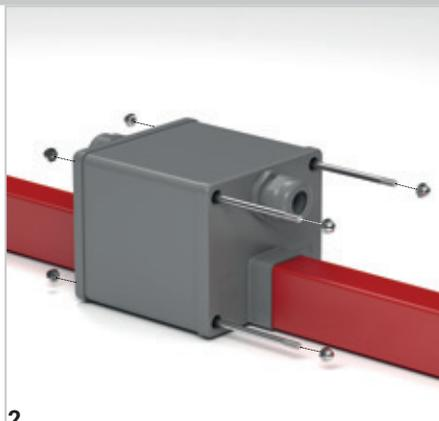

2 Put the feeding cables through the cable gland and connect them to the conductors.

TBE - END CLOSURE

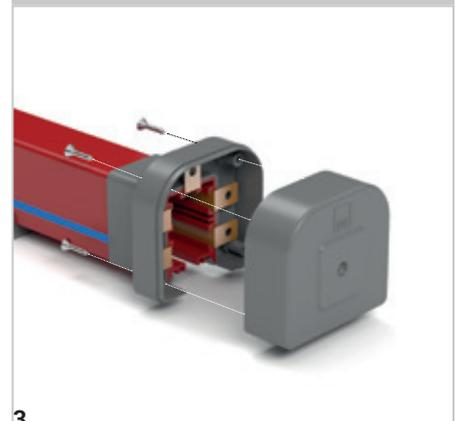

3 Install the end closure to the end of the housing and screw it.

▶▶ DESIGN FORM

Member List		
Serial No	Type	Pcs.

Company :	
Project :	
Project No :	
Name :	
Date :	
Signature :	
Prepared by	



Please use this page after copying.

►► OFFER REQUEST FORM

Date :

Project Name	:	<input type="text"/>
Company	:	<input type="text"/>
Name Surname	:	<input type="text"/>
Tel	:	<input type="text"/>
E-Mail	:	<input type="text"/>
Address	:	<input type="text"/>

General Data

Track Length	:	<input type="text"/>
Number of Cranes on Track	:	<input type="text"/>
Crane Travel Speed	:	<input type="text"/>

Environmental Data

Operating Environment	:	<input type="checkbox"/> Indoor	<input type="checkbox"/> Outdoor
Ambient Temperature	:	<input type="text"/> °C min.	<input type="text"/> °C max.
Other Operating Conditions (Humidity, Dust, Chemical Influence, etc.)	:	<input type="text"/>	

Electrical Data

Operating Voltage	:	<input type="text"/> Volts	<input type="checkbox"/> AC	<input type="checkbox"/> DC			
		<input type="text"/> Phases	<input type="checkbox"/> N	<input type="checkbox"/> PE			
Position and Number of Feeder	:	<input type="text"/> from End	<input type="text"/> from Middle				
Duty Cycle (%)	:	<input type="checkbox"/> 50%	<input type="checkbox"/> 60%	<input type="checkbox"/> 70%	<input type="checkbox"/> 80%	<input type="checkbox"/> 90%	<input type="checkbox"/> 100%

Motor Specifications	Crane - 1		Crane - 2		Crane - 3	
	Power (kW)	Current (A)	Power (kW)	Current (A)	Power (kW)	Current (A)
Hoist motors	<input type="text"/>	<input type="text"/>	<input type="text"/>	<input type="text"/>	<input type="text"/>	<input type="text"/>
Auxiliary motor	<input type="text"/>	<input type="text"/>	<input type="text"/>	<input type="text"/>	<input type="text"/>	<input type="text"/>
Long travel	<input type="text"/>	<input type="text"/>	<input type="text"/>	<input type="text"/>	<input type="text"/>	<input type="text"/>
Cross travel	<input type="text"/>	<input type="text"/>	<input type="text"/>	<input type="text"/>	<input type="text"/>	<input type="text"/>

Options

Brackets Required	:	<input type="checkbox"/> Yes	<input type="checkbox"/> No
Repair Zone Required	:	<input type="checkbox"/> Yes	<input type="checkbox"/> No
Collector Replacement Required:		<input type="checkbox"/> Yes	<input type="checkbox"/> No
		<input type="text"/> Qty	<input type="text"/> Qty

Descriptions	:	<input type="text"/>
--------------	---	----------------------

►► Declaration

CE DECLARATION OF CONFORMITY

Product Group E-Line TB Trolley Busbar Systems
Manufacturer Akcaburgaz Mahallesi, 3114. Sokak,
No:10 34522 Esenyurt-Istanbul

The objects of the declaration described below is in conformity with the relevant Cable gland harmonisation legislation. This declaration of conformity is issued under the sole responsibility of the manufacturer.

Standard:**TS EN 61439-6**

Low-voltage switchgear and controlgear assemblies - Part 6: Busbar trunking systems

CE - Directive:

2014/35/EU "The Low Voltage Directive"

2014/30/EU "(EMC) Electromagnetic Compatibility Directive"

2011/65/EU "RoHS Directive"

Technical Document Preparation Official:

EAE Elektrik Asansor End. Insaat San. Tic. A.S.
Akcaburgaz Mahallesi, 3114. Sokak, No:10 34522 Esenyurt-Istanbul

Emre GÜRLEYEN

Date

20.04.2016

Document Authorized Signatory

Elif Gamze KAYA OK
Deputy General Manager



PRODUCT TYPES



BUSBAR ENERGY DISTRIBUTION SYSTEMS



CABLE TRAYS



TROLLEY BUSBAR ENERGY DISTRIBUTION SYSTEMS



INDOOR SOLUTIONS

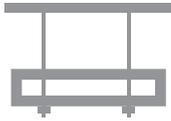

SUPPORT SYSTEMS



EAE Elektrik A.S.
Head Office
Akcaburgaz Mahallesi,
3114. Sokak, No:10 34522
Esenyurt - Istanbul - TURKEY
Tel: +90 (212) 866 20 00
Fax: +90 (212) 886 24 20

EAE DL 3 Factory
Busbar
Gebze IV Istanbul Makine ve
Sanayicileri
Organize Bolgesi, 6. Cadde,
No: 6 41455 Demirciler Koyu,
Dilovası - Kocaeli - TURKEY
Tel: +90 (262) 999 05 55
Fax: +90 (262) 502 05 69

Please visit our website for the updated version of our catalogues.
www.eaeelectric.com



IEC 61439-6



Catalogue 08-Eng. / Rev 09 / 500 pcs. 02/09/2022
S.S.

EAE has full right to make any revisions or changes on this catalogue without any prior notice.